

Sump tray with DIBt-approval	
Dimension	820 x 1220 x 1050 mm
Material	Polyethylene
Colour	black
Approval number	Z-40.22-327
Weight	20 kg
Sump capacity	220 litres
Load capacity	500 kg



Description / Application:

Safety sump trays are required where substances hazardous to water are used, stored or transported. The tray is a safety measure to avoid that unplanned leaking liquids contaminate the soil or groundwater. With a tray the environment and your hall floor are protected as well as your employees for whom leaking liquids can provide a hazard. Advantages of plastic trays are et al. the low tare weight and the easy handling. KIGA trays are thermoformed in one piece and thus have no welding seams which can leak or become leaky. The trays provide a high resistance against most acids and lyes, lubricants and oils.

Information on sump capacity required:

A sump tray has to collect 10 % of the stored liquid quantity, however, at least the quantity of the largest container.

Example:

20 canisters à 20 l = 400 litres
here applies: 10 % of the total quantity = 40 litres

Example 2:

10 canisters à 20 l + 1 barrel with 200 l = 400 litres
here applies: at least largest container = 200 litres

(This calculation is a non-binding rule of thumb for containers up to 1000 litres and can vary depending on the type of substance. Basically, the law applies, et al. of WHG (German Water Resources Act)).

Load Quantities:

Quantity / Storing position:
up to 4 pieces

Drawings:

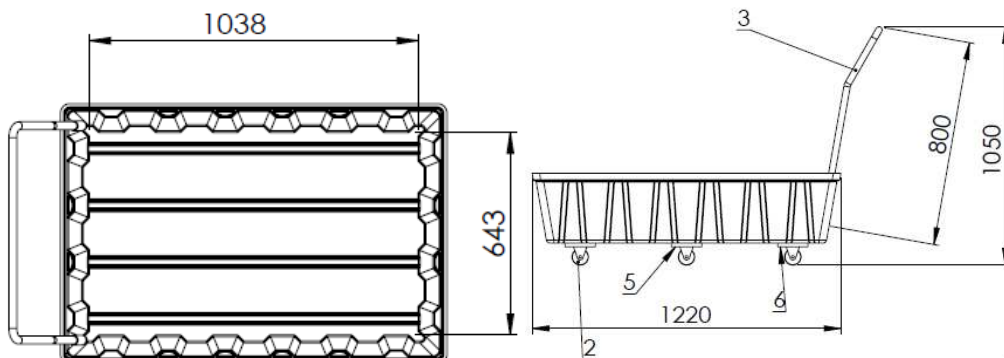

*All load capacity data is only valid in case of evenly distributed load. For all indicated dimension tolerances of +/- 3 mm apply.